

INSTRUCTIONS

HE10 SERIES ELECTRIC HEATING UNIT

WARNING

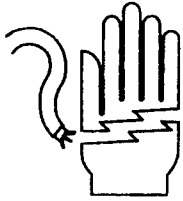

1. INSTALLATION MUST BE MADE AND MAINTAINED IN STRICT ACCORDANCE WITH NATIONAL/LOCAL PLUMBING AND NATIONAL/LOCAL ELECTRICAL CODES (CSA IN CANADA). INSTALLATION MUST BE MADE BY A QUALIFIED ELECTRICIAN. THE APPLICABLE PROVISIONS OF THE ABOVE MENTIONED CODES TAKE PRECEDENT. IMPROPER ELECTRICAL INSTALLATION AND MAINTENANCE MAY RESULT IN SERIOUS INJURY OR DEATH FOR PERSONNEL OR LIVESTOCK.
2. EACH ELECTRIC UNIT MUST BE WIRED THROUGH A FUSED SWITCH BOX AND FUSED ACCORDING TO AMPS REQUIRED FOR EACH SPECIFIED ELECTRIC UNIT. SEE EXHIBIT B. CANADIAN ELECTRICAL CODE--PART 1 REQUIRES LIVESTOCK WATERERS INSTALLED IN FEEDLOTS IN OPEN FEEDING AREAS TO BE GROUNDED BY A SEPARATE STRANDED COPPER GROUNDING CONDUCTOR OF AT LEAST NO. 6 AWG TERMINATING AT A POINT WHERE THE BRANCH CIRCUIT RECEIVES ITS SUPPLY.
3. THIS UNIT MUST BE GROUNDED TO A COPPER GROUND ROD 5/8" (1.6 cm) DIAMETER BURIED AT LEAST 10 FEET (3.1 meters) IN UNDISTURBED SOIL. SEE EXHIBIT B.

1 TEMPERATURE ADJUSTMENT: The thermostat is pre-set at the factory for economical ice-free use (about 40° F, 4° C). To adjust your specific installation temperature, turn the temperature control knob clockwise to increase the temperature of the water (1/4 turn equals about 4° F). Only small adjustments should be made at one time. One complete turn is the maximum at any one time. The small light in the thermostat will glow when the element is on.

To recalibrate you will need a container of water about 40° F. Place a bulb in water. The indicator light should come on. If not, turn adjusting screw slowly until light comes on. This will calibrate the unit to turn on at approximately 40° F. It is advisable to remove the heating unit during the summer months. The minimum summer precaution is to turn off electricity to the unit.

2 WIRE AND FUSE SELECTION: Check charts below for correct fuse size (Table 1) and wire size (Table 2) for your specific waterer. All heating units are 115V-AC unless otherwise specified.

Table 1 - Fuse Size

Waterer Model	Heater Model	Ratings Watts	At 115V Amps	Waterer Model	Heater Model	Ratings Watts	At 115V Amps
80B2/M70	HE10522	650	5.7	WC92, WD62, WE52	HE108	1100	8.7
MA31/WMA31	HE1035	250	2.2	WG24/MG24	HE1013	500	4.4
MC32/WMC32	HE1035	250	2.2	WG26/MG26	HE1014	750	6.5
MF30/WMF30	HE1031	500	4.4	WG28/MG28	HE1015	1000	8.7
MJ31/WMJ31	HE1035	250	2.2	WG212/MG212	HE1016	1250	11.8
MK32/WMK32	HE1035	250	2.2	WL3	HE103	325	2.8
ML30/WML30	HE1031	500	4.4	WM2, WC90, WD60, WE50	HE106	600	5.2
WA7	HE101	325	2.8	WR1	HE104	400	3.5
WBA1	HE1011	1450	12.2	WS1	HE102	250	2.2
WBA2	HE1012	1700	13.4	MH30, WMH30	HE1031	500	4.4
WC91, WD61, WE51	HE107	850	7.0				

¹For straight resistance load, Amps = Watts/volts; therefore at 120 volts, amps are reduced.

Table 2 - Voltage Drop

MINIMUM SIZED AWG COPPER WIRE REQUIRED TO ALLOW NOT MORE THAN 2% VOLTAGE DROP¹

TOTAL HEATER RATINGS 115V		LENGTH OF CIRCUIT (ONE WAY) IN FEET					
WATTS	AMPS	50	100	160	200	280	360
250	2.2	14 ²	14	14	14	12	10
325	2.8	14	14	12	12	10	8
600	5.2	14	12	10	10	8	6
750	6.5	14	10	8	6	6	6
800	7.0	12	10	8	6	6	5
1000	8.7	12	8	6	6	5	4
1400	12.2	12	8	6	6	4	2
1600	13.9	12	8	6	4	4	2

¹Mechanical strength is not considered; overhead spans over 50 feet should be no less than #8 AWG; under 50 feet no less than #10 AWG.

²#14 AWG is smallest wire allowed regardless of circuit length.

CAUTION: When installing and/or servicing this unit, be certain the disconnect switch is locked in the "off" position.

3

If your Heating Element Wires are **Black - Red - Green** (Some older models):

The **Green** (ground) wire is secured in the box.

The **Red** wire connects to the **Red** wire from the control.

The **Black** wire connects to the **White** (neutral) wire from the control and power source.

If your Heating Element Wires are **Red - White - Green** (current models):

The **Green** (ground) wire is secured in the box.

The **White** wire connects to the **White** (neutral) wire from the control and power source.

The **Red** wire connects to the **Red** wire from the control.

(If your element wires are **Black - White - Green**, wire **Black** to **Red**)

When there are multiple heating elements involved, twist the wire ends together and secure with wire nuts.

Exhibit A is the wiring illustration for the electric unit on all current waterer models.

4

TROUBLE SHOOTING FOR A QUALIFIED ELECTRICIAN ONLY: IF the new unit fails to operate after installation; OR the unit has been installed and working and then begins to freeze up; OR after installation of a new component part, heating element, or thermostat, the unit fails to operate, check the following:

WATER FREEZES:

- Make sure the electric unit is getting 115 Volts of electricity. If no electricity is present, turn off the main fuse box to the unit. Check all wire connections to make sure they are correct and tight. Check all fuses in the line and then turn on electricity.
- Make sure water trough is clear of mud and silt; mud can insulate the heating element and thermostat from the water.
- Turn temperature adjusting screw 1/4 turn clockwise - check to see if indicator light is on - if not, turn adjusting knob one more 1/4 turn clockwise. One quarter turn is about 4° F.
- Check to see that the temperature sensing end of probe is submerged below water level but does not touch bottom of trough.
- If electric unit is on and the waterer still has freeze-up or icing trouble, check the line voltage at the unit when the full load on that line is operating. Low voltage will greatly reduce the heating capacity of the heating element.

If none of the above results in proper operations, then:

- Turn off electricity at fuse box.
- Remove cover from junction box inside waterer.
- Completely remove the thermostat from the waterer to avoid short-circuit possibilities. Then wire the heating element directly to your line leads. Connect the **red** wire from the heating element to the **white** (neutral) wire from the fuse box, connect the **black** wire from the heater to **black** (hot) from your fuse box and **green** heater to **green** (ground).
- Turn on electricity; if element heats, thermostat needs to be replaced. (Highway 16 West, P.O. Box 2000, Houghton, Iowa 52631).
- Turn on electricity; if element does not heat, element must be replaced.

WATEROVERHEATS

- Turn temperature control screw counter-clockwise--1/4 turn at a time and not over a 1/2 turn. Then check the waterer in a couple of hours or the next morning. If temperature is still too warm, repeat procedure.
- If adjusting temperature control screw fails to correct overheating, replace thermostat. Return immediately if still under warranty.

5

OFF SEASON MAINTENANCE; For extended life of the electric unit remove the units from the waterers in the spring and store in dry area. Check the units in the fall before installing in the waterers and you will have less trouble during the heating season.

EXHIBIT A WIRING ILLUSTRATION

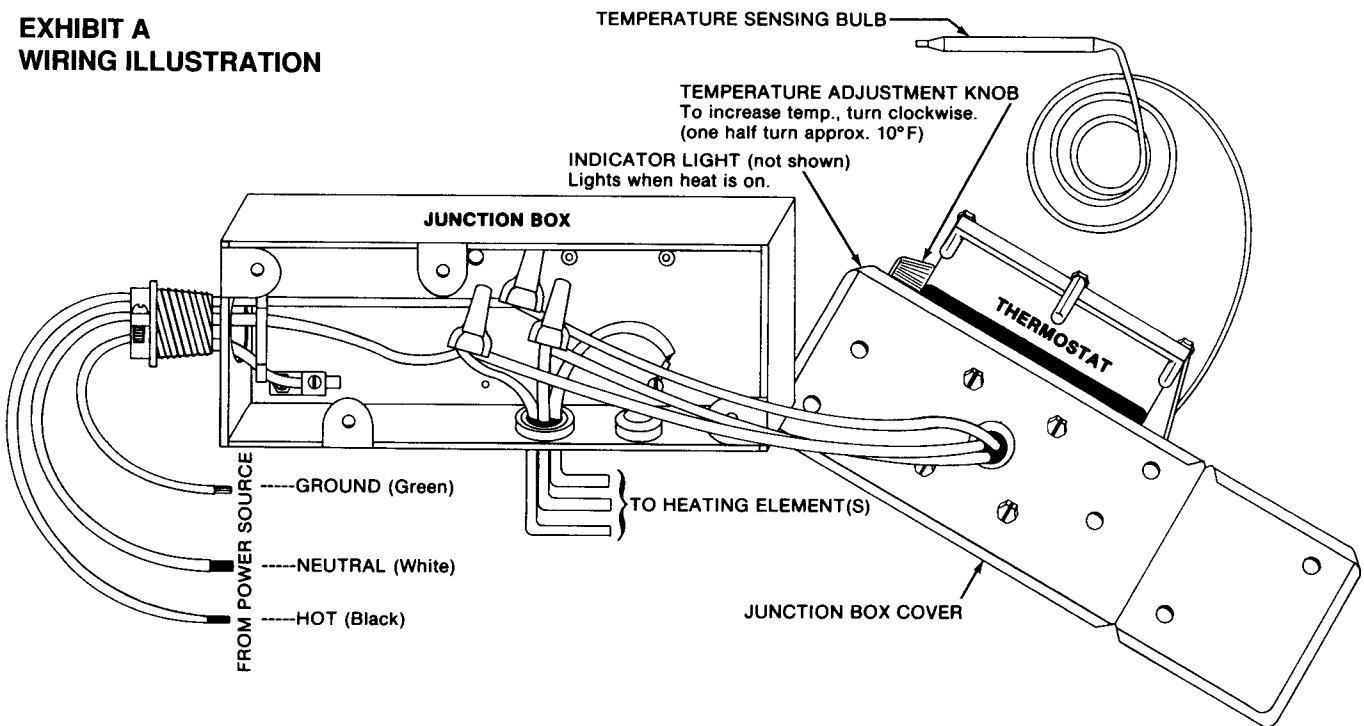

The unit will not function properly unless all wires are connected exactly as shown in these instructions.

WARNING: Installation must be in strict accordance with National Electrical Code (Canadian Electrical Code in Canada) and local codes. Improper electrical installation and maintenance may result in serious injury or death for personnel or livestock.

Connections in the junction box are as follows:

1. **The Black wire** from thermostat fastens to the incoming hot wire.
2. **All White wires** (one from thermostat, each heating element, incoming neutral) fasten together.
3. **All Red wires** fasten together (this is the switched wire from the thermostat).
4. **All Green or ground wires** fasten to junction box.

"Make sure all wire connections are tight!"

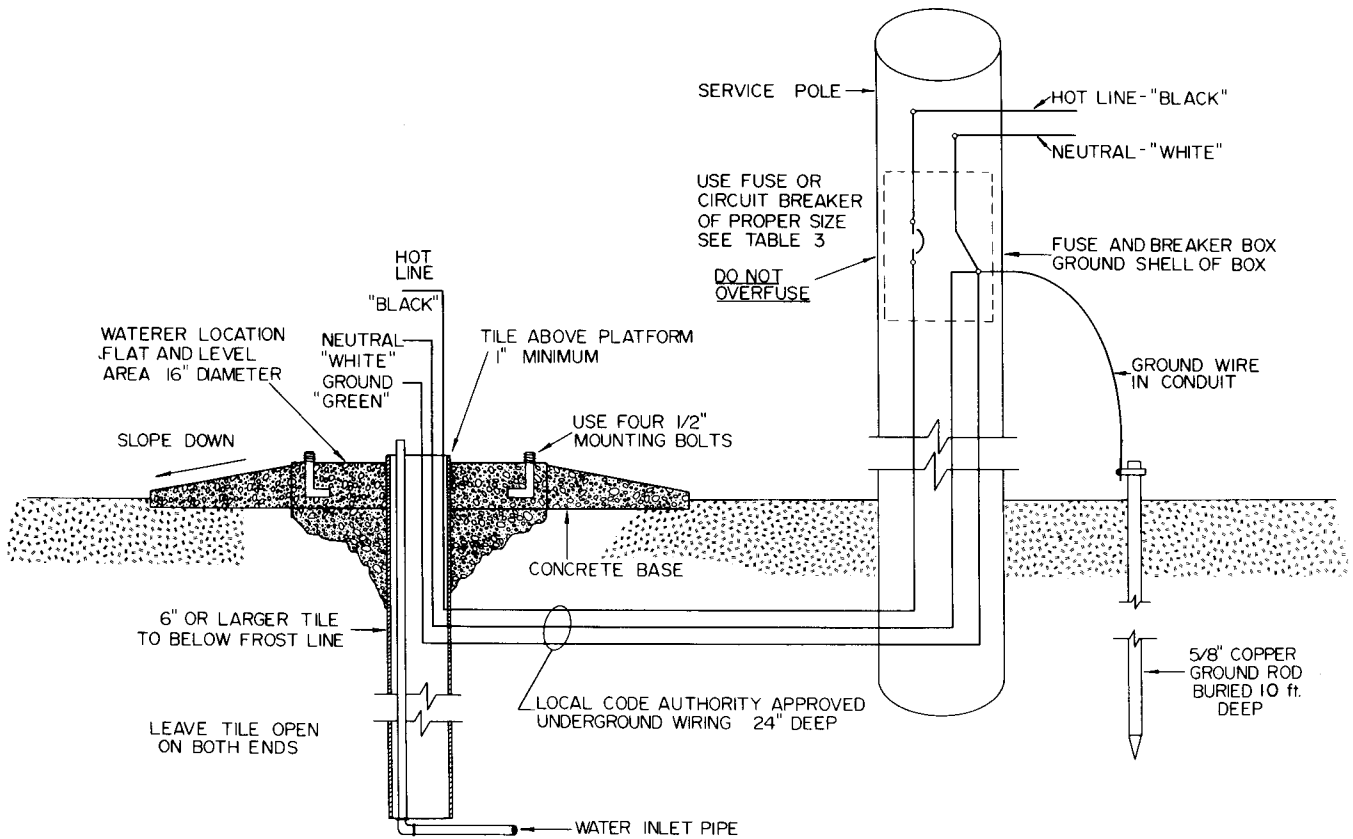

EXHIBIT B

NOTE: Check local codes. Some jurisdictions require 2 ground rods.

6 The dealer you purchased your waterer from should normally have parts available. However, should he be temporarily out, he will order parts for you. Keep your equipment in good repair and it will give you many years of good service. Please fill out the warranty card and return immediately.

WARRANTY

The model HE10 Electric Heating Unit in all heated waterers carries a two year guarantee. All electric units will be repaired at no charge during the warranty period, provided they have been registered with the manufacturer on the card which accompanies the waterer. If the heating unit shows signs of customer abuse, it will be repaired but at the customer's expense. The manufacturer reserves the right to repair the defective unit or replace it with a new unit if the cost of repair is prohibitive. When the warranty period has expired or a unit is returned that has not been registered for warranty, it will be repaired or replaced and the customer charged accordingly.

All other parts of heated waterers are also covered with a one-year guarantee from the date of purchase against defects due to materials and workmanship. Warranted components should be returned to your dealer for shipment to our factory--Highway 16 West, P.O. Box 2000, Houghton, Iowa 52631.



PO BOX 2000 • HOUGHTON, IOWA 52631 • USA
 TELEPHONE 319-469-4141 FAX 319-469-4402