

INSTRUCTIONS AND REPAIR PARTS LIST

SF74 - GRO-FAST™ HOG FEEDER - BROWER
SF74P - GRO-FAST™ HOG FEEDER - PRIDE OF THE FARM

READ ALL DIRECTIONS CAREFULLY BEFORE BEGINNING INSTALLATION

TOOLS REQUIRED: Straight Blade Screwdriver, Phillips Screwdriver, Adjustable Wrench or 3/8" Wrench, Center Punch.
Assembly time is about one hour. One person assembly is possible, but some steps go a lot better with an additional helper.

SF74 And SF74P Parts List

Ref. No.	Part No.	Description	Qty	Repair
1	9341	Trough Assembly	1	*
2	9227	Hopper Side	2	*
3	9344	Front and Back Panel	2	*
4	17435	Lower Panel	2	*
5	9326	Feed Slide Adjustment	2	*
6	9232	End Brace Angles (for Lid Rods)	2	*
7	13892	5/16" x 24-1/4" Lid Rod, Zinc	3	*
8	13884	Lid	4	*
9	17434-18	Top Cover	1	*
9334 - SF74 and SF74P Hardware Bag contains Ref. No. 14-26.				
10	9319	Trough Brace	2	*
11	9231	Corner Brace	4	*
12	13885	Top Hinge, 11H/22H/SF74	2	*
13	OF182	1/4"-20 x 1/2" Philips Pan Head Machine Bolt, Zinc	64	
14	OF55	1/4"-20 Hex Nut, Zinc	64	
15	OF113	1/4" Split Lockwasher, Zinc	64	
16	OF160	5/16"-18 Cold Forged Wing Nut, Zinc	4	
17	OF214	10-24 x 1/2" Slotted Round Head Machine Bolt, Zinc	2	
18	OF53	10-24 Hex Nut, Zinc	2	
19	OF78	1/8" x 3/4" Steel Cotter Pin, Zinc	3	
20	OF121	5/16" Flat Washer, Zinc	6	
21	OF120	1/4" Flat Washer, Zinc	4	

Parts available for repair have an asterisk (*) in the repair column.

MODEL NUMBER

The MODEL NUMBERS are: SF74 GRO-FAST™ HOG FEEDER - BROWER
SF74P GRO-FAST™ HOG FEEDER - PRIDE OF THE FARM

WHEN ORDERING PARTS

- (1) Show MODEL NUMBER and NAME: Example - SF74 GRO-FAST™ HOG FEEDER - BROWER
- (2) Show PART NUMBER and FULL DESCRIPTION of part: Example - 9341 Trough Assembly

HOW TO ORDER PARTS

Repair Parts may be ordered from your dealer.



PO BOX 2000 • HOUGHTON, IOWA 52631 • USA
PHONE 319-469-4141 FAX 319-469-4402
www.hawkeysteel.com E-mail: sales@hawkeysteel.com



ISHSF74
REV. 3.0
PRINTED IN U.S.A.

ASSEMBLY INSTRUCTIONS

DO NOT TIGHTEN ANY FASTENERS UNTIL INSTRUCTED TO DO SO!

When assembling this feeder, the side from which the lid is raised will be considered as the front and the right and left ends will be determined when facing the front.

STEP 1

Attach both Lower Panels (Ref. No. 4) on the inside of the Trough Assembly (Ref. No. 1). The lower panel is mounted so that the pre-welded bolt threads face outwardly and with the threads on the lower side. Only bolt the bottom holes using 1/4"-20 Bolt, 1/4" Lockwasher, and 1/4"-20 Nut (Ref. Nos. 13, 14 & 15).

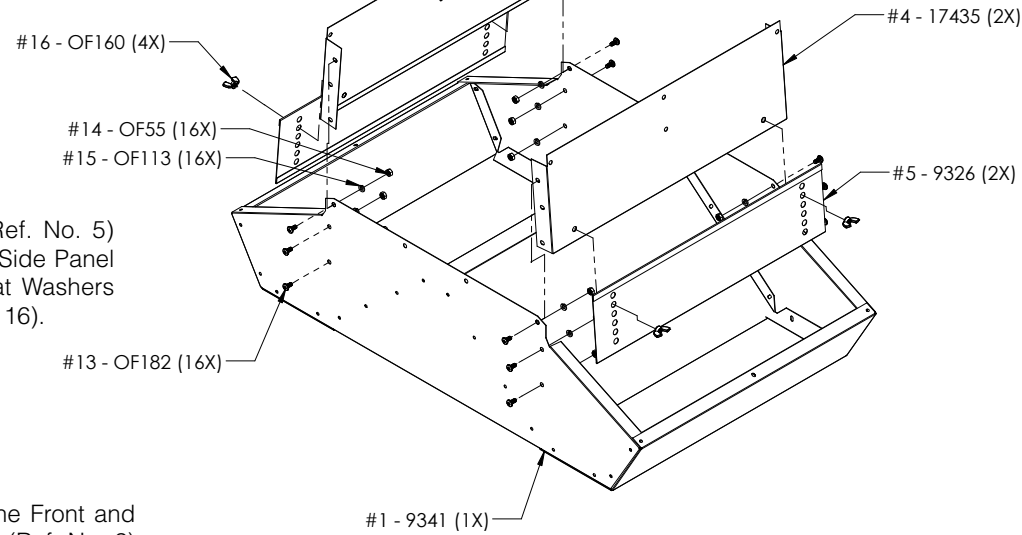

Mount the Feed Adjustment Panel (Ref. No. 5) on the pre-welded bolts on the Lower Side Panel Assembly (Ref. No. 4). Use 5/16" Flat Washers and 5/16" Wing Nuts (Ref. Nos. 20 and 16).

STEP 2

Attach Hopper Sides (Ref. No. 2) to the Front and Back Panels (Ref. Nos. 3). The Sides (Ref. No. 2) go out and over the front and back panels. Bolt and finger tighten all hopper section fasteners except for the bottom four corners. These holes will be used to mount the hopper to the trough on STEP 3. Use Fasteners (Ref. Nos. 13, 14 & 15).

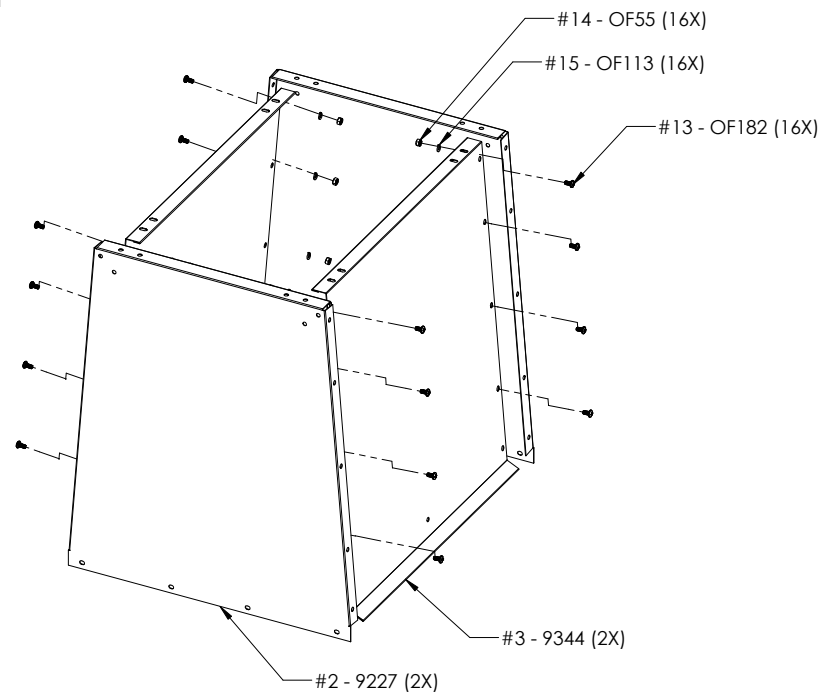

STEP 3

This step will probably be best facilitated with a second helper as the bolts may be hard to reach. Lift the partially assembled hopper onto the trough. The hopper edges go out and over the trough edges. Align the bottom holes in the hopper and the top holes on the trough end. Install using 1/4"-20 Bolt, 1/4" Lockwasher, 1/4"-20 Nut (Ref. No. 13, 14 & 15). A fastener goes in the center hopper hole (toward the bottom edge) and through the Lower Side Panel Assembly (Ref. No. 4) on each side.

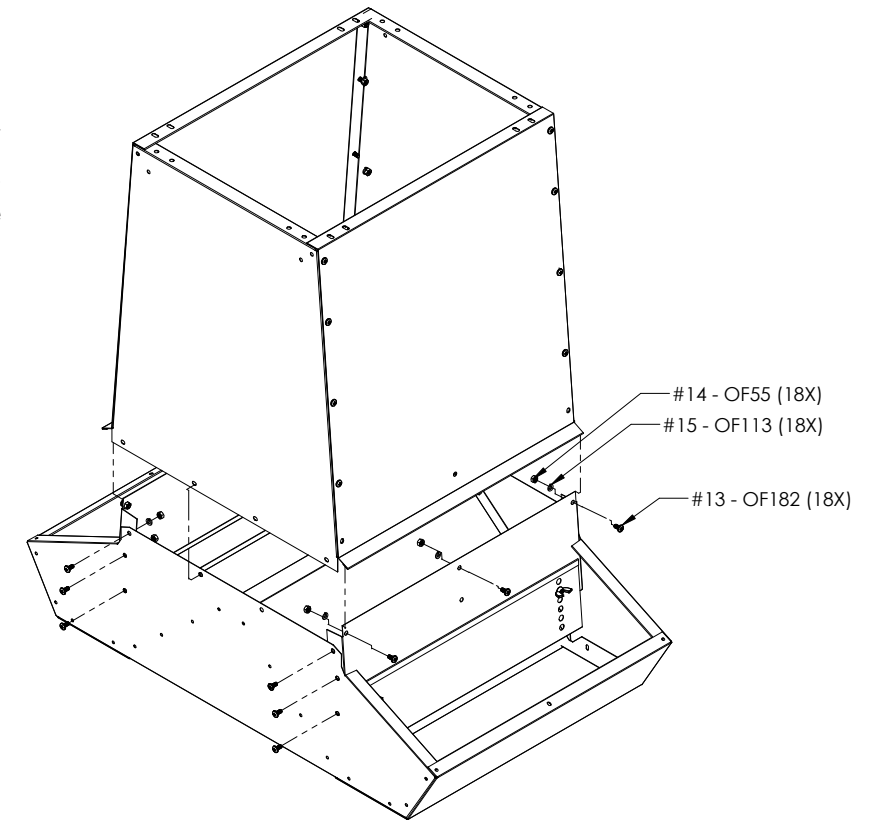

STEP 4

Locate the End Brace Angles (Ref. No. 6). End brace angles are mounted with the holes against the trough and down. Using a center punch, align the holes that go through the angle, the Hopper Side (Ref. No. 2) and the Trough Assembly (Ref. No. 1). Install using 1/4"-20 Bolt, 1/4" Lockwasher, 1/4"-20 Nut (Ref. Nos. 13, 14 & 15). Repeat on the other side.

Tighten all fasteners which have been inserted at this time.

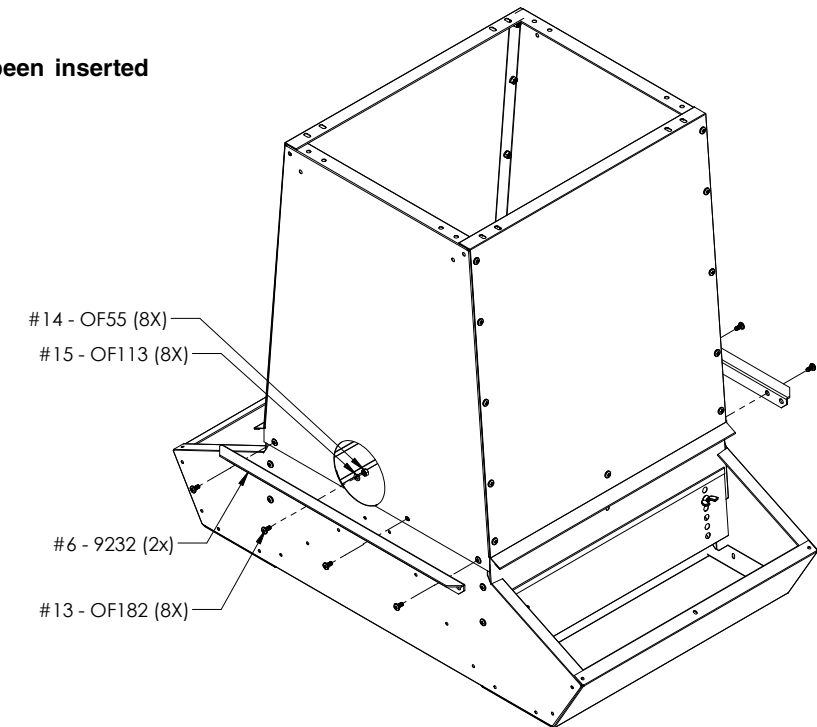

STEP 5

Attach Trough Brace (Ref. No. 10) to the trough lip with the 10-24 Bolt, Lockwasher and Nut (Ref. Nos. 17, 15 & 18). Also attach trough brace to the Lower Side Panel Assembly (Ref. No. 4) using a 1/4"-20 Bolt, Lockwasher and Nut (Ref. No. 13, 14 & 15). Repeat on the other side. Do not tighten any of these fasteners until after STEP 6 is complete.

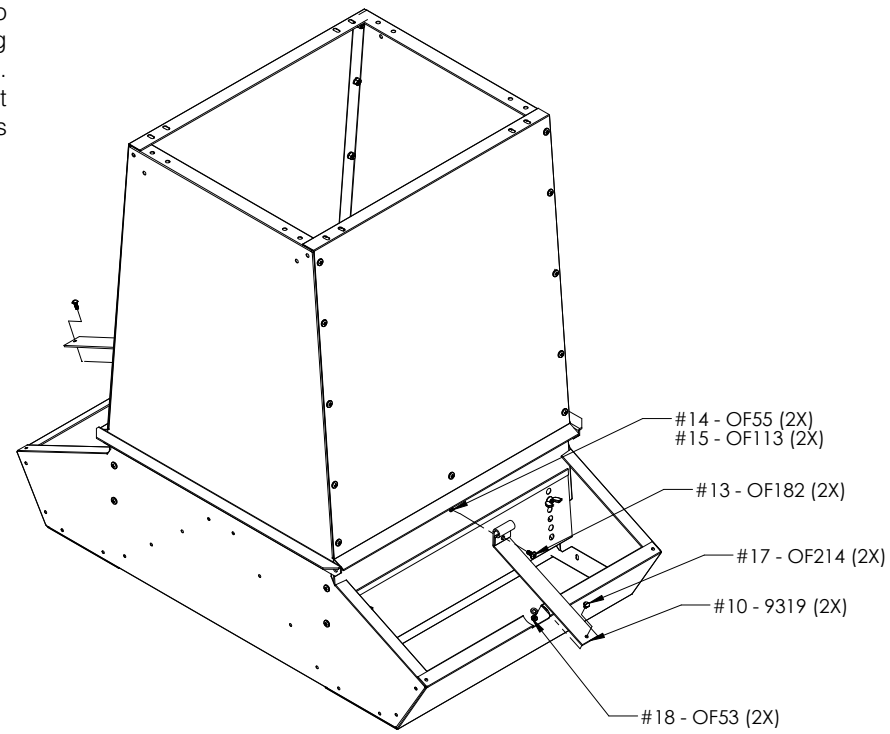

STEP 6

Locate Trough Lids (Ref. No. 8) and Lid Rods (Ref. No. 7). Place one 5/16" Washer (Ref. No. 20) on a lid rod. Put the rod through the holes on the End Brace Angle (Ref. No. 6). Push rod through the first lid, through the center Trough Brace (Ref. No. 10), then through the second lid, and finally through the hole on the opposite end brace angle. Add another 5/16" Washer and secure with a Cotter Pin (Ref. No. 19). Repeat on the other side. Now tighten the fasteners on the Trough Brace (Ref. No. 10).

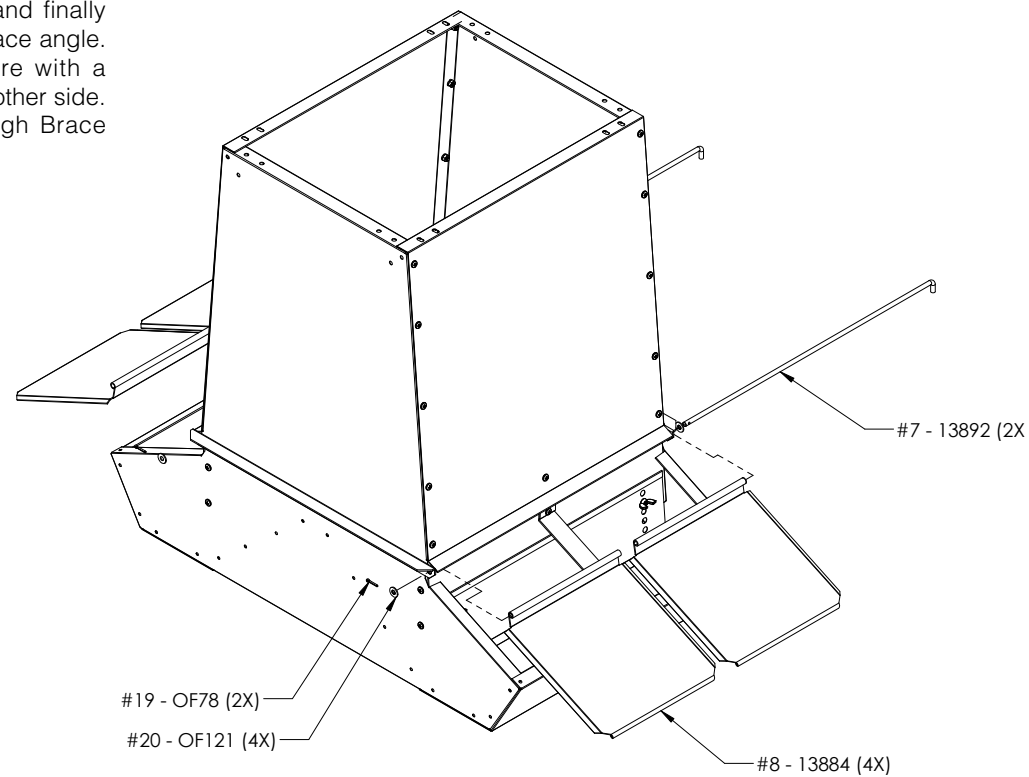

STEP 7

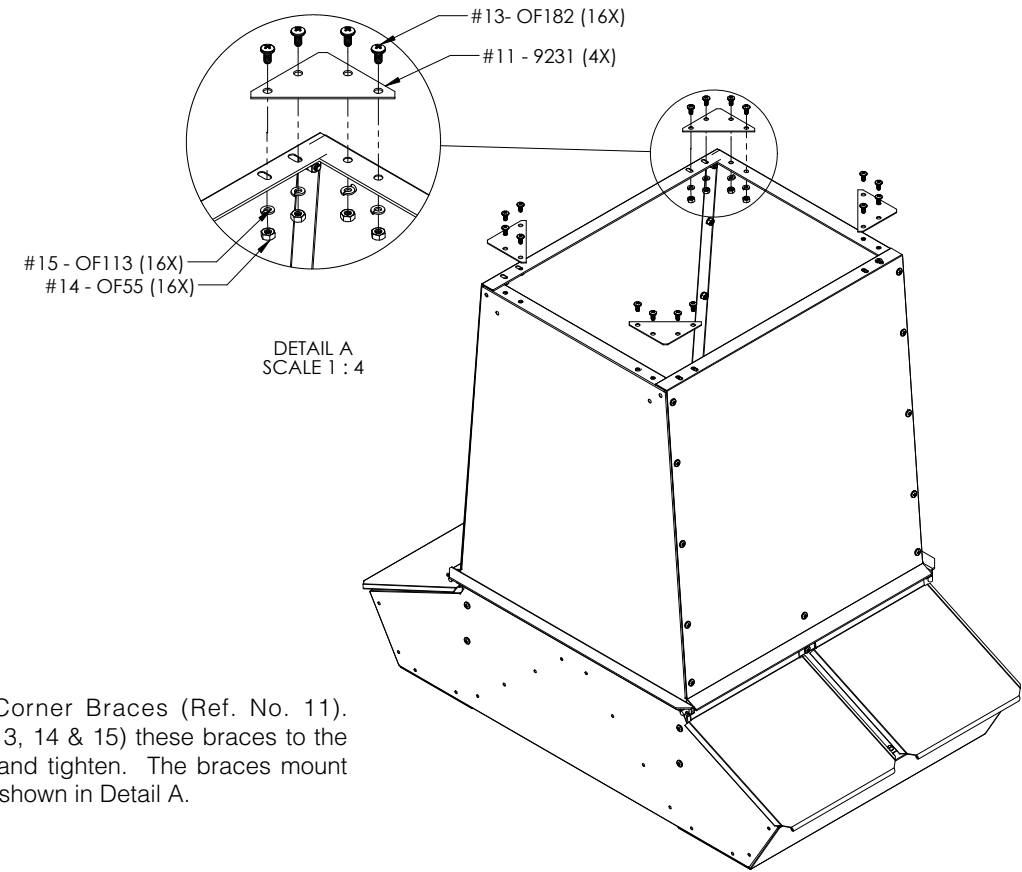

Locate the four Corner Braces (Ref. No. 11). Fasten (Ref. Nos. 13, 14 & 15) these braces to the top of the hopper and tighten. The braces mount on top of the lip as shown in Detail A.

STEP 8

Assemble both Hinges (Ref. No. 12) to the cover using Fasteners (Ref. Nos. 13, 14, & 15). Do not tighten these fasteners until the Hinge Rod (Ref. NO. 7) is inserted through the Hinge (Ref. No 2) and Cover (Ref. No. 9). Fill extra hole in Hopper Side (Ref. No. 2) with Fasteners (Ref. No. 13 & 14). Tighten fasteners just enough to insure that the cover will still lay flat.

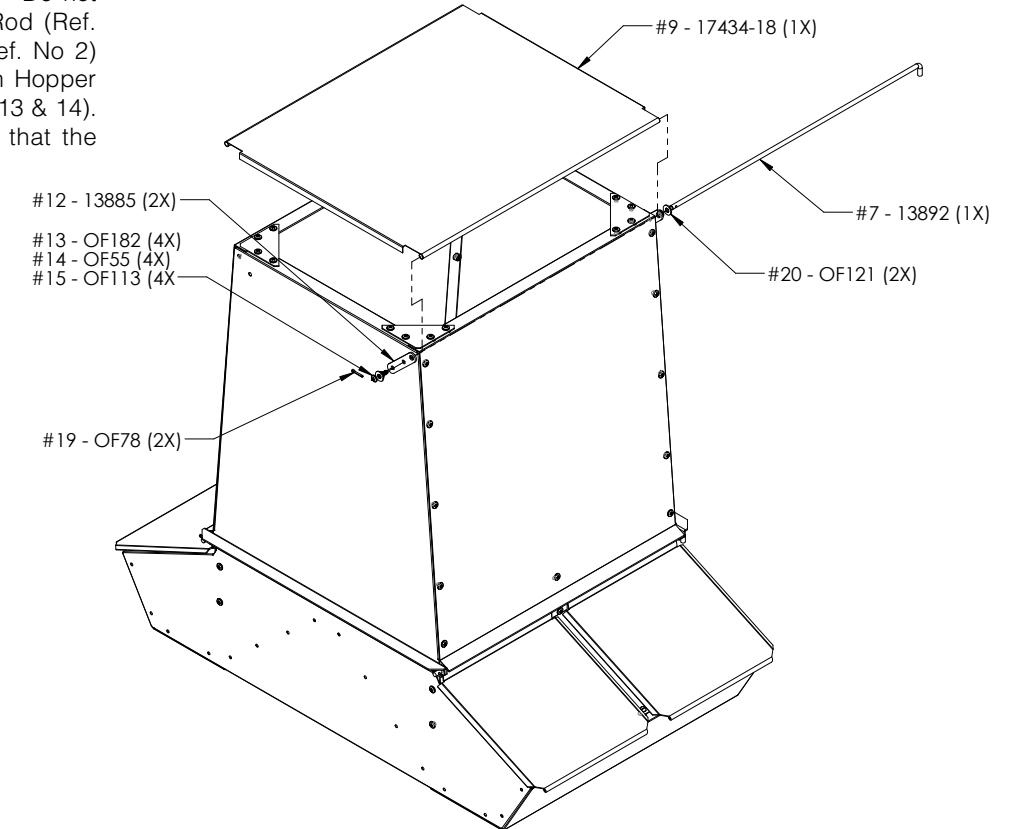

STEP 9

Set the feeder on a level surface and make sure that your assembly is square. Now double check to see that all fasteners are tight. Extra hardware may remain. Your feeder is now ready for use.

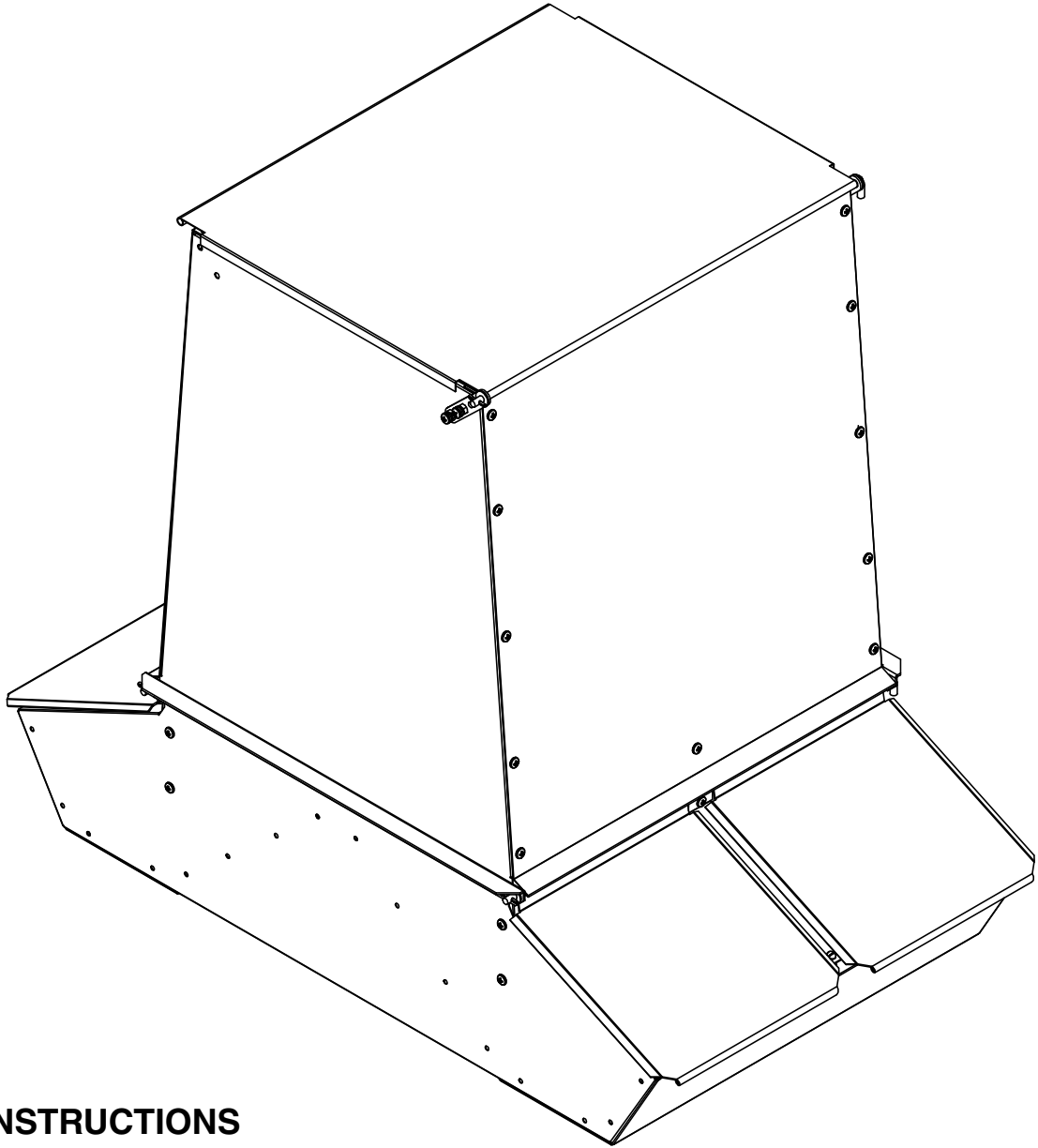

SF74/SF74P

OPERATING INSTRUCTIONS

The Feed Slide Adjustment (Ref. No. 6) at the bottom of the feed trough may be adjusted for various kinds of feed. Always keep the adjustments low enough so that the troughs are only partly full. This will minimize feed waste.

Should feed become caked or bridged in the hopper, simply lift the lid and loosen feed until it flows freely. This will not be necessary unless the feed becomes damp.

CAUTION: Do not attempt to move feeder when full of feed.